



Student A

Ask, answer and complete.

How much is ...?

How much are ...?

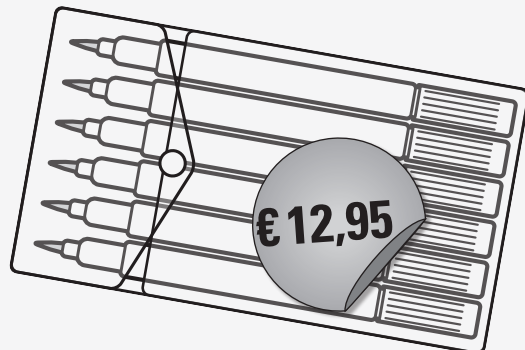
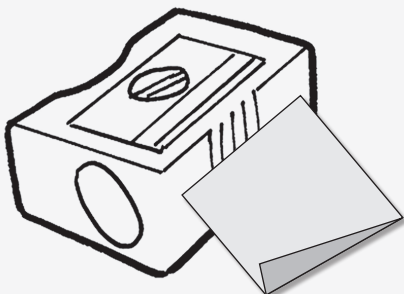
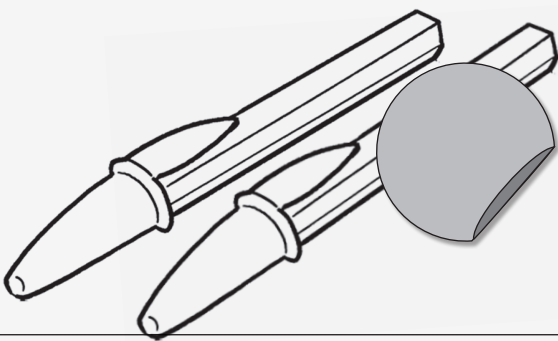
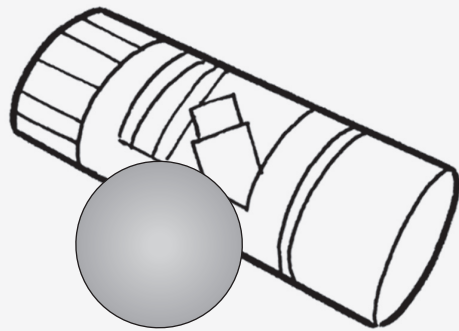
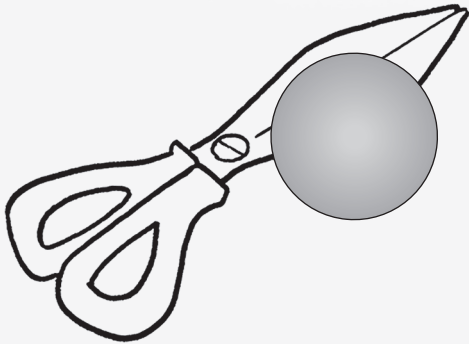

Student B

Ask, answer and complete.

How much is ...?

How much are ...?

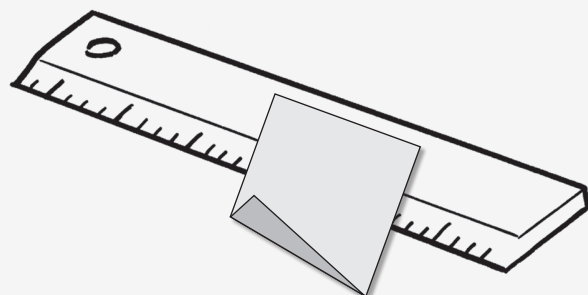
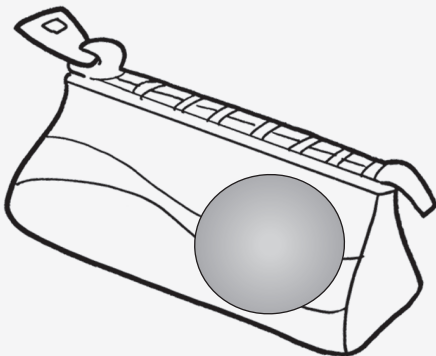
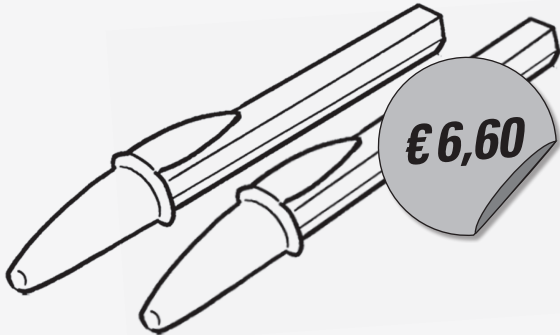
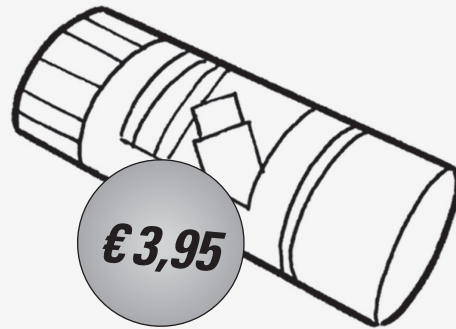
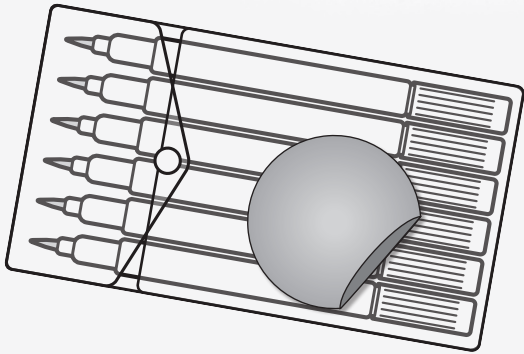

1 Use a dictionary. Look up and write.

basin

[n] UK 🇬🇧

headphones

[n, pl] UK 🇬🇧

purse

[n] UK 🇬🇧

lamp

[n] UK 🇬🇧

chest of drawers

[n] UK 🇬🇧

curtain

[n] UK 🇬🇧

blanket

[n] UK 🇬🇧

phone charger

[n] UK 🇬🇧

carpet

[n] UK 🇬🇧

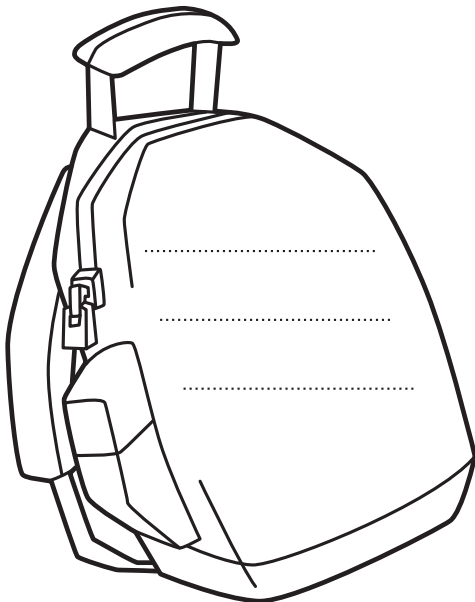

bag

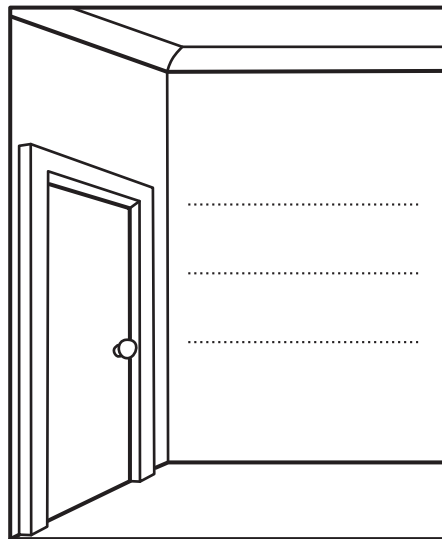

bedroom

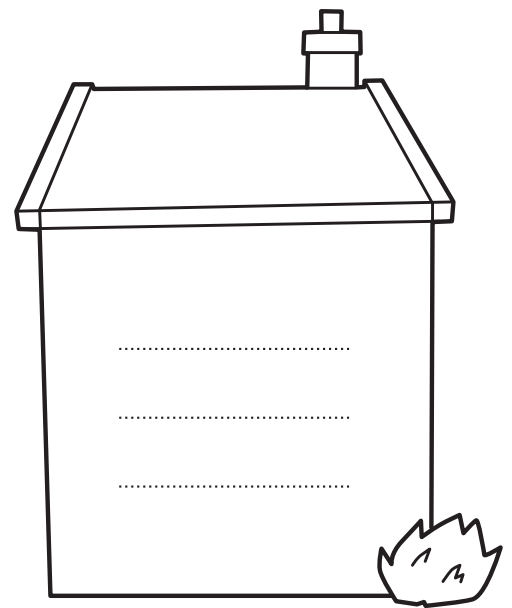

house

2 Look at page 112 of the Language Book. How do you pronounce these words?

basin

[n] UK 🇬🇧 /'beɪsən/

blanket

[n] UK 🇬🇧 /'blæŋkɪt/

charger

[n] UK 🇬🇧 /'tʃɑːdʒər/

curtain

[n] UK 🇬🇧 /'kɜːtən/

drawer

[n] UK 🇬🇧 /drɔːr/

purse

[n] UK 🇬🇧 /pɜːs/

You can check your answers at:

<http://dictionary.cambridge.org/dictionary/learner-english/>

Cut out and put in order.

I'm sorry. Those green shoes are for volleyball.

I want to go home and watch sports on TV! Goodbye!

What for? This T-shirt is for basketball. That T-shirt over there is for volleyball. And that yellow T-shirt is for running. What do you want?

Yes, please. I'd like some running shoes. How much are these shoes here?

Can I help you?

Oh! I see. And those blue shoes in the box over there. Are they running shoes?

Well, these shoes here are for running in the country. And those shoes over there are for running ...

OK! Stop it, please! Can I have a T-shirt?

Those shoes aren't for running, they're for basketball.

Right. Then where are the shoes for running?

No, they're not. They're for cycling.

Oh! OK. Then can I try on those green shoes over there?



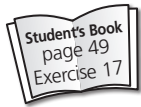

1 Read and tick (✓) the answers.

1 How much are the sweets?

- £100 for 99 grams
- £1.99 for 100 grams
- 99p for 100 grams

2 What does the girl buy in the market?

- oranges and tomatoes
- bananas and tomatoes
- oranges and bananas
- oranges, bananas and tomatoes

3 What does the boy order?

- apple juice
- orange juice
- apple juice and some food

4 What does the boy need for school?

- grey trousers
- a grey shirt and trousers
- a school jacket
- dark blue trousers

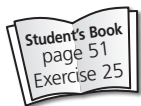

2 Read carefully and tick (✓) T true or F false. Write the number of the part of the text where you can find the answer.

1 Hi there! My name's Ben. I'm from Halifax in Canada. Find out more about me here.

2 This chessboard is from Spain. My aunt travels a lot and she brings me presents. At home I play chess with my dad. He's good! I go to the school chess club too. It's fun.

I collect stones. These are some of the stones from my collection. When I go to a new place, I look for a new stone. **3** Every summer we go camping in the Rocky Mountains and I find a lot of cool stones there. My favourite is black and it's from a volcano.

4 This is Spark. She's four years old and she's my best friend. I take her for walks and she sleeps on the floor in my room. She's sitting under my desk now. I play with her a lot too.

You can see two of my cool things in this photo.

5 I'm sitting on my bike. It's quite new and I love it. I ride it to school every day. I'm wearing a new jacket too. In the photo I'm in the yard in front of my house, but you can't see it very well. It's my favourite place in the world!

T F

1 Ben's got a pet.

.....

2 He can play chess.

.....

3 He's from Canada.

.....

4 He goes camping in summer.

.....

5 He walks to school.

.....

6 He goes on holiday to Spain.

.....

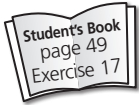

1 Listen again and number in the order you hear them.

Anything else?

Can I have some sweets, please?

Can I help you?

Good afternoon, madam.

Have you got any orange juice?

Here you are.

How much are they?

That's all.

Is that all?

No, sorry.

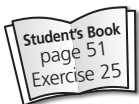

2 Read again and complete the notes.

Topic: My favourite things

- 1 chessboard present from aunt from
- 2 collection stones from every I go to, lots from the
- 3 pet, years old, sleeps, take for
- 4 quite new, every day
- 5 new wearing in photo

Favourite place: front yard

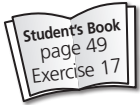

1 Work with a partner. Choose one of the shopping pictures. Act out a new conversation.

Student A

You are the customer. Make a list of five things you need to buy.

Your bus home leaves soon and you are in a hurry.

Student B

You are the shop assistant. It's a bad day and you are very tired. Your mobile phone is ringing. It's your friend. You want to talk on the phone.

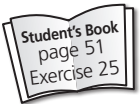

2 Make a mind map about your favourite things.

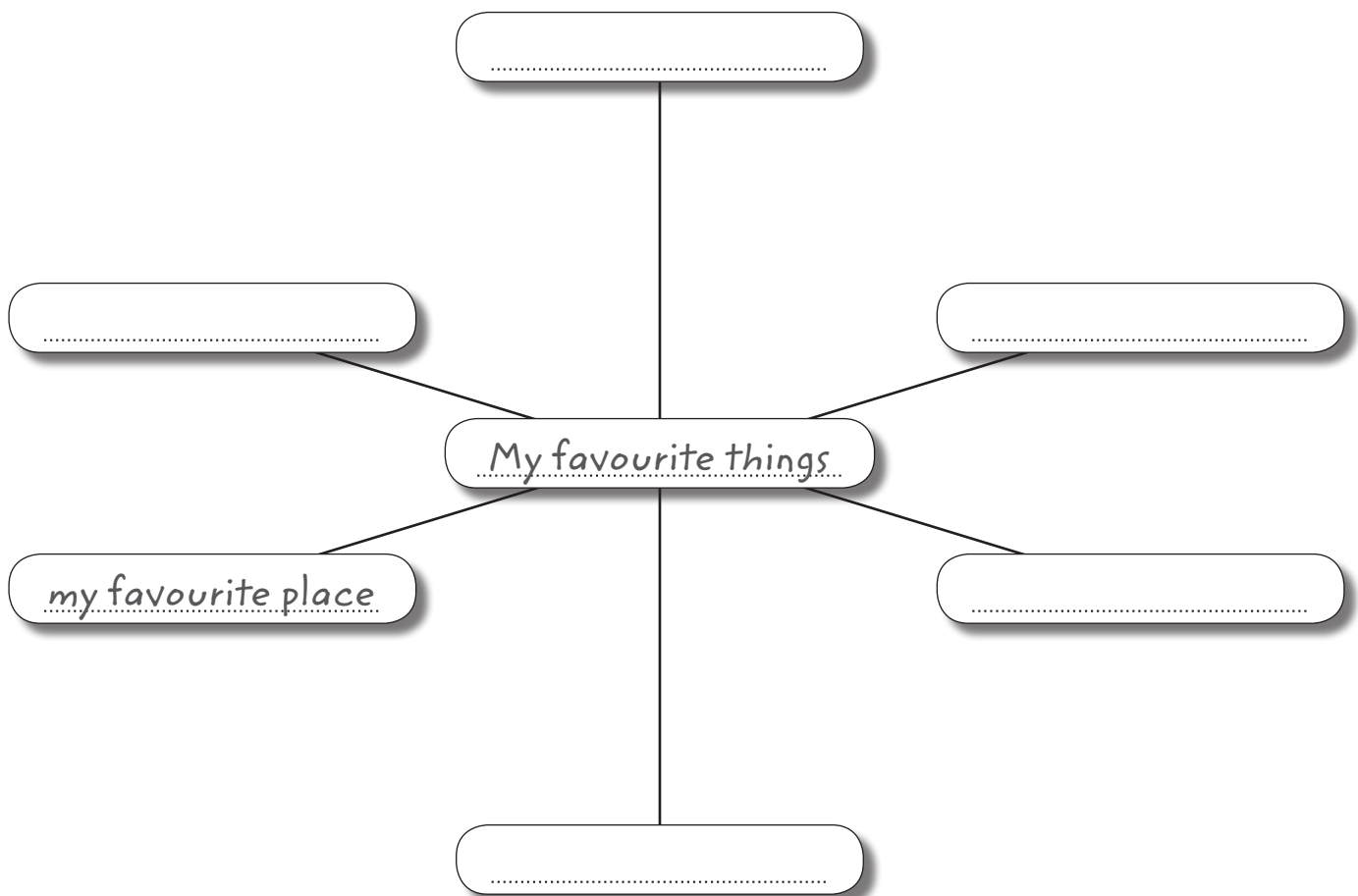

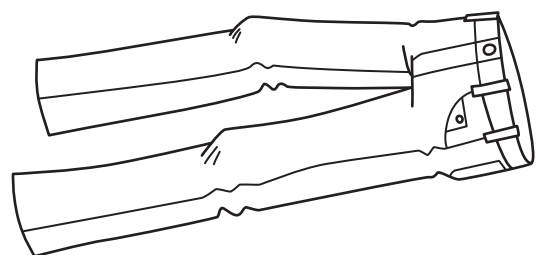
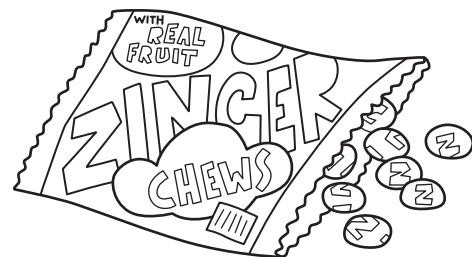
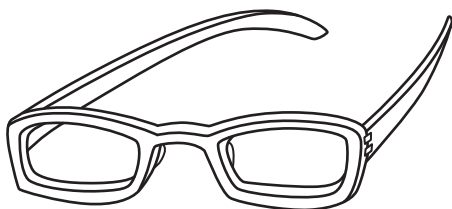
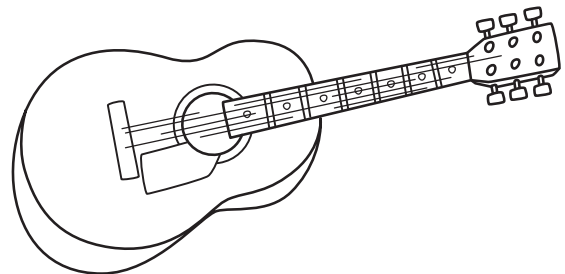
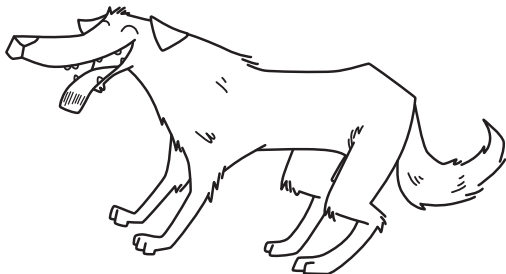
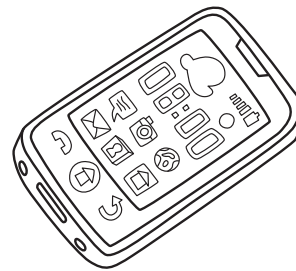
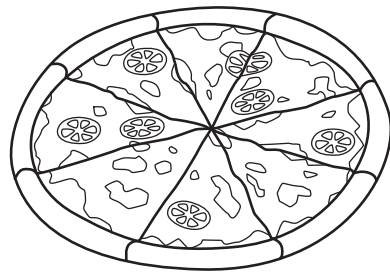
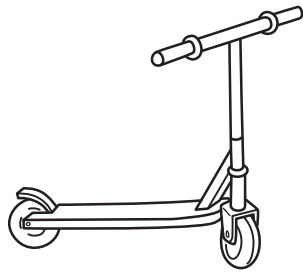

Listen and complete.

It's Halloween today,
 And there's a party
 We're all dressed up,
 It's a terrible sight!
 We're saying 'Trick or treat?'
 To everyone we
 The monsters are coming to !

this evening / tonight

meet / see
 play / town

There's my friend Rose,
 In the pointed
 She's wearing a black dress,
 And she's carrying a
 Her face is painted
 And purple – fancy that!
 The monsters are coming to town!

hat / nose

frog / cat
 black / green

My brother's over there,
 And he's all in
 You can't see his face,
 'Cos he's a ghost tonight.
 He's running down the
 Whoo-hoo! What a fright!
 The monsters are coming to town!

red / white

garden / road

You see I'm wearing a
 And it's long and
 My face is black and white,
 And there are horns on my
 I've got pointed teeth,
 And I look half-dead!
 We're the monsters and we're in !

cloak / dress
 black / red

hat / head

school / town

Read, calculate and write the answers.



<p>Leela is shopping with her friends. She buys a T-shirt for \$9.99, a pair of trousers for \$25, two pairs of socks for \$1.99 each and a sweater for \$15. How much money does she spend?</p> <p>She spends</p>	<p>Your dad gives you a pass for the sports centre for a year. It costs £300. He makes 12 payments for it – one each month. How much does he pay a month?</p> <p>He pays a month.</p>
<p>Tom gets £5 pocket money a week. He spends £3 and he saves £2 each week. How much money does he save a month? And how much a year?</p> <p>Tom saves a month. He saves a year.</p>	<p>Harriet buys a large pizza with 16 slices and eats half of it. She puts it in the fridge. The next morning she eats 2 slices for breakfast. How many slices does she have for lunch? What proportion of the original pizza are they?</p> <p>She has slices for lunch. They are of the original pizza.</p>
<p>Daniel has got €50. He goes shopping to buy some new things for school. He buys a school planner for €7, a pencil case for €12.50 and a set of felt tip pens for €10.75. Then he goes to a café and spends €2.95 on a sandwich.</p> <p>How much does he spend?</p> <p>How much has he got left?</p>	<p>Sam buys a packet of sweets in a newsagent's. He eats half of them and then he gives the rest to his sister, Katie. Katie eats 8 of the sweets and then she puts 10 away for the next day. How many sweets are there in a packet?</p> <p>There are sweets in a packet.</p>

Student A

1 Calculate and write the ingredients for 24 people.

Complete this column first.



Ingredients for 12 people	Ingredients for 24 people	Ingredients for 6 people
150 grams butter		
200 grams chocolate		
½ cup coconut		
2 cups breakfast cereal		
1 banana		



Ask your partner and complete this column.

2 Work with a partner. Ask, answer and complete.

How much butter do you need for 6 people?

Seventy-five grams.



Student B

1 Calculate and write the ingredients for 6 people.

Complete this column first.



Ingredients for 12 people	Ingredients for 6 people	Ingredients for 24 people
150 grams butter		
200 grams chocolate		
½ cup coconut		
2 cups breakfast cereal		
1 banana		



Ask your partner and complete this column.

2 Work with a partner. Ask, answer and complete.

How much butter do you need for 24 people?

Three hundred grams.